



## Chinatungsten Online

### (Xiamen) Manu. & Sales Corp.

Chinatungsten Online (Xiamen) Manu. & Sales Corp. (CTOMS) is a special TUNGSTEN manufacturer and exporter in Mainland of China. In the past 2 decade, CTOMS has enjoyed rich successful experience in manufacturing and supplying tungsten relevant products, especially tungsten heavy alloy series for various applications.

Our tungsten alloy bears the high density ranging 15.4-18.5g/cc (70-97W) with the components of W-Ni-Cu, W-Ni-Fe Or W-Ni-Cu-Fe and etc, for different applications of:

**Burking bar:** A kind of aircraft riveting tool, used to absorb the force of rivet guns, reducing the vibration of bucking.

**Crankshaft:** Sometimes casually abbreviated to crank, is the part of an engine, which translates reciprocating linear piston motion into rotation.

**Defense applications of kinetic energy penetrator,** including tungsten alloy cube, ball, and ring for armor piercing...

**Counterweight for racing car, yacht, aircraft and etc.**

**Radioactive shields for x-rays and other nuclear radiation**

**Sports fittings parts (darts, golfs, fishing sinker)**

**Bob for mobile phone**

**Military and Other Applications**

**ANVILOY**

More details and products' pictures can be found on our site of [www.chinatungsten.com](http://www.chinatungsten.com). Please check and find anything useful for you. Just feel free to contact us upon any inquiry and for any question with many thanks.

## Tungsten Bucking bars

Bucking bars made of tungsten provide increased weight (density) to allow riveting in confined areas. The weight to size ratio provides good kinetic energy transfer and will expedite the installation process.

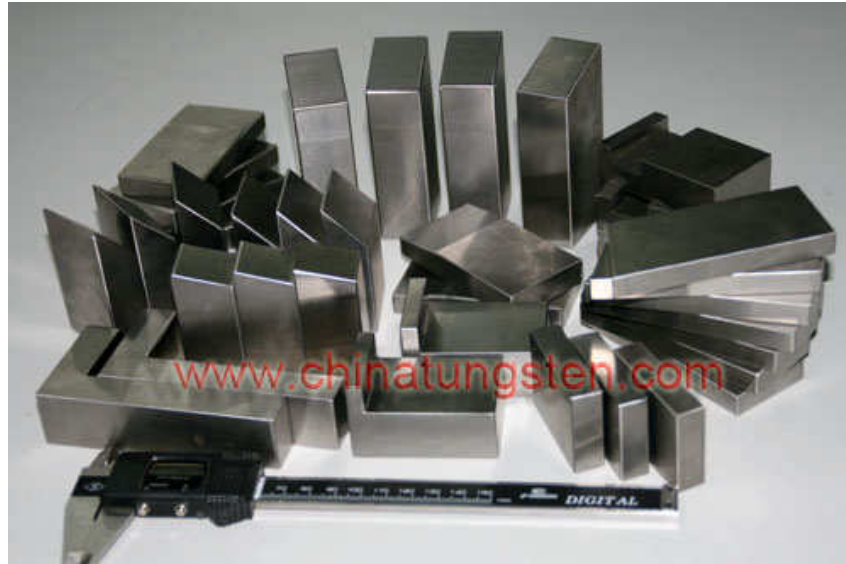

### **The best choice—Tungsten Heavy alloy (WHA) bucking bar!**

With the advantage of being **more than twice as dense as steel**, tungsten bucking bar now becomes the best choice for riveting, especially for the confined spaces. With a suitable bucking bar, you will make the task easier and perfect, meaning less rivets to drill out.

According to the investigation for different bucking bars of the same shape but different materials and mass characteristics, use of heavier but same sized tungsten bucking bars can reduce vibration transmission to the hand.

In a word, tungsten bucking bars are **VERY** useful for bucking rivets and will make your life much easier in the build process.

## Our Tungsten Heavy Alloy (WHA) Bucking Bars

1. At **CTOMS**, all of our bucking bars of this list are made of 95% tungsten. All edges are deburred and working surfaces are polished for troubles-free use.
2. It is also possible to have "custom" bars made to your specifications if a quantity is needed. At CTOMS we manufacture our own bucking bars.
3. Price Validity: On or before Beijing Time, May 15th, 2009.

**CODE :**

WHA BB H 001

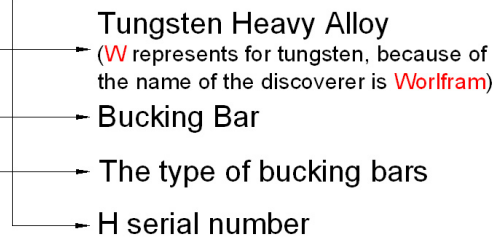

- TYPE:**
- H TYPE: Bucking bar whose shape looks like "H"
  - L TYPE: Bucking bar whose shape looks like "H"
  - P TYPE: Bucking bar whose shape looks like "p"
  - U TYPE: Bucking bar that with one or two "U" groove
  - T TYPE: Bucking bar whose shape looks like "Triangle"

**TYPE H SERIES**

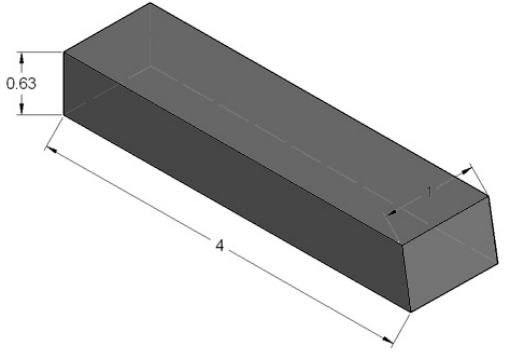
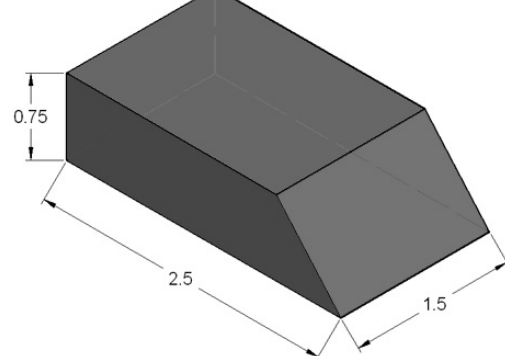
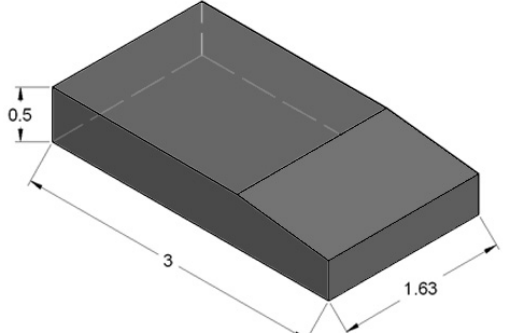
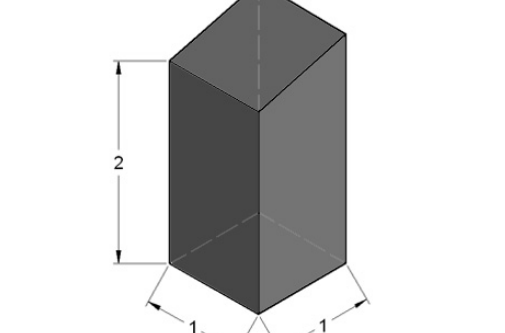
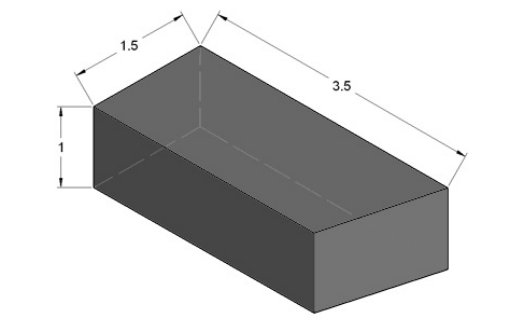
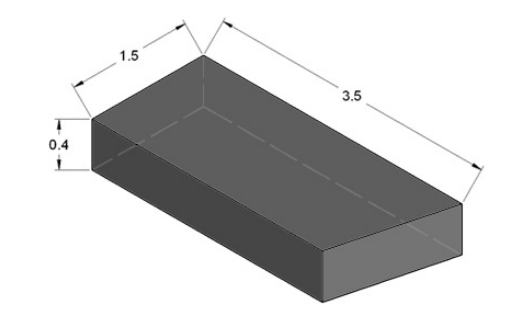
			
<p><b>WHABBH001</b></p>	<p><b>WHABBH002</b></p>		
<p>N.W. (KG/PC)</p>	<p>0.74</p>	<p>N.W. (KG/PC)</p>	<p>0.71</p>
			
<p><b>WHABBH003</b></p>	<p><b>WHABBH004</b></p>		
<p>N.W. (KG/PC)</p>	<p>0.69</p>	<p>N.W. (KG/PC)</p>	<p>0.64</p>
			
<p><b>WHABBH005</b></p>	<p><b>WHABBH006</b></p>		
<p>N.W. (KG/PC)</p>	<p>1.48</p>	<p>N.W. (KG/PC)</p>	<p>0.59</p>

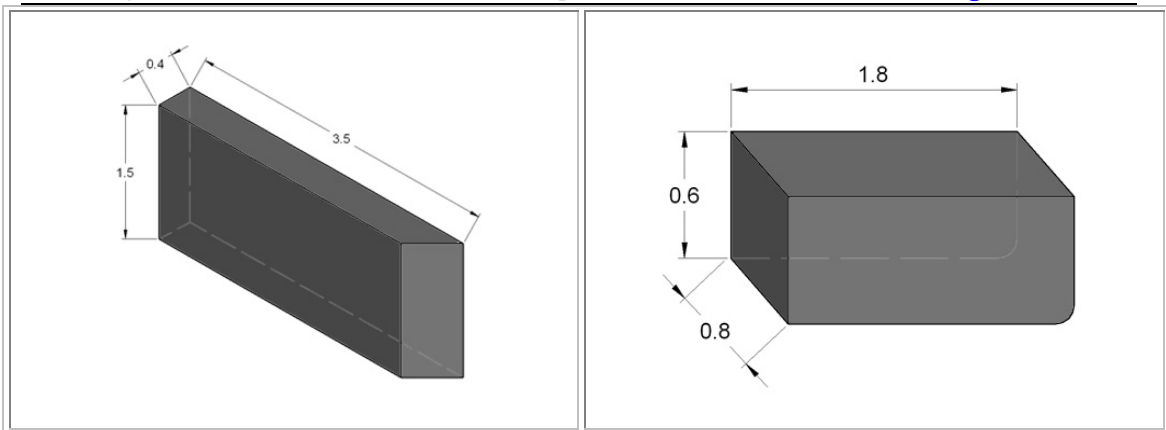

WHABBH007

WHABBH008

N.W. (KG/PC)

0.59

N.W. (KG/PC)

0.25

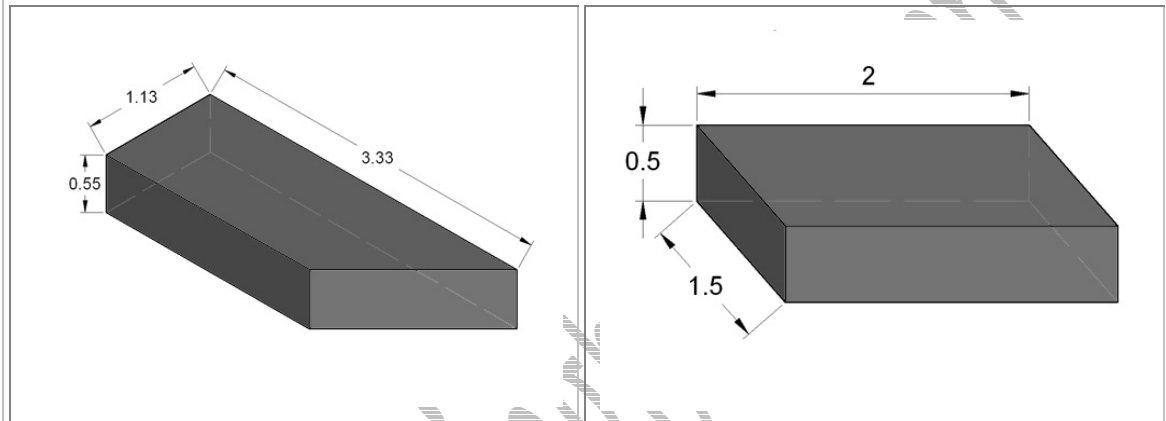

WHABBH009

WHABBH010

N.W. (KG/PC)

0.66

N.W. (KG/PC)

0.45

**TYPE L SERIES**

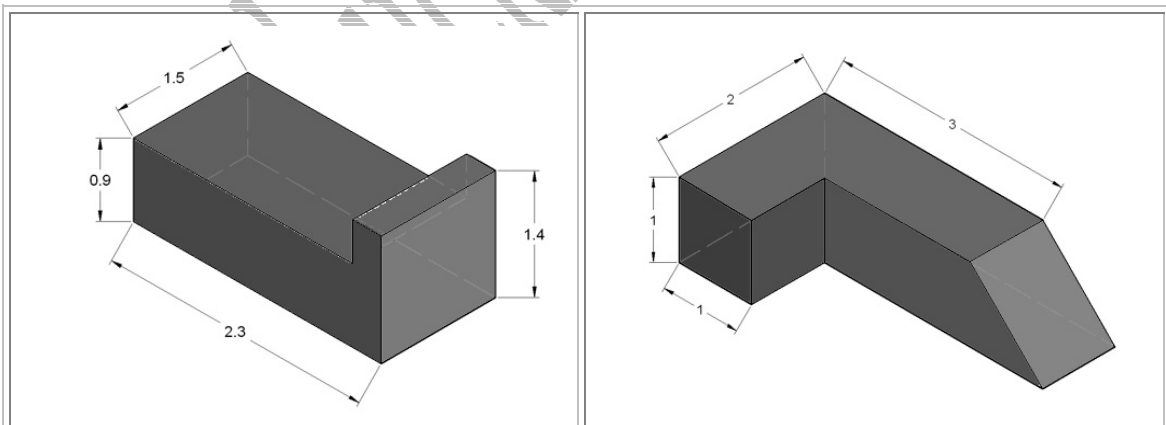

WHABBL001

WHABBL002

N.W. (KG/PC)

1.00

N.W. (KG/PC)

1.12

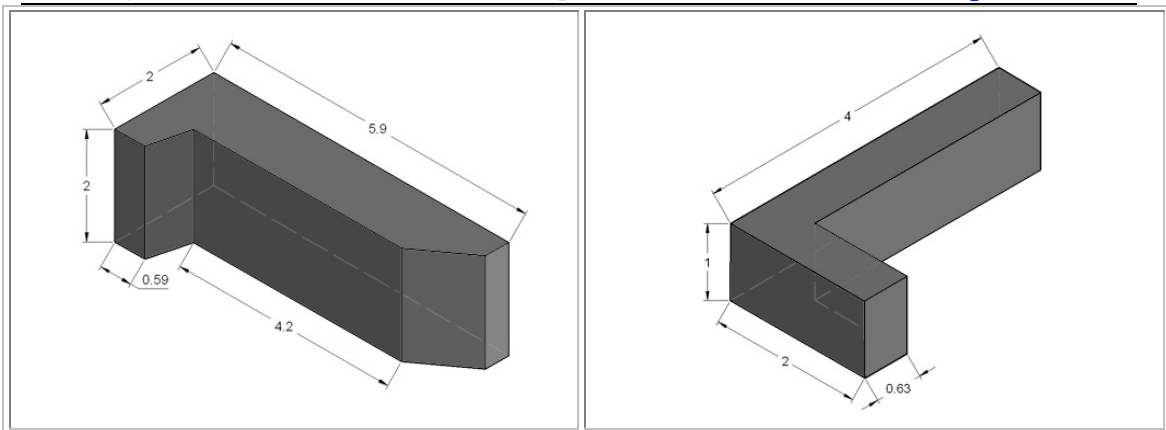

WHABBL003

WHABBL004

N.W. (KG/PC)

4.20

N.W. (KG/PC)

1.00

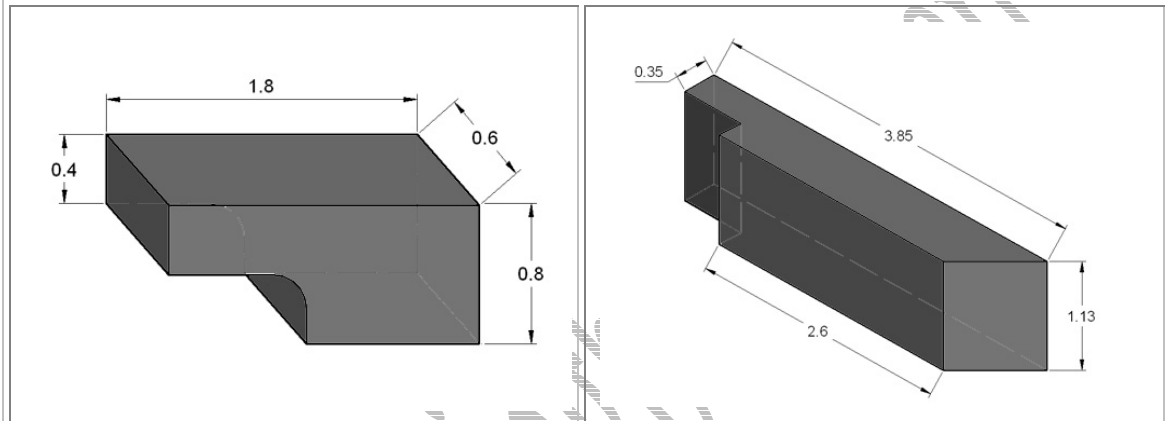

WHABBL005

WHABBL006

N.W. (KG/PC)

0.25

N.W. (KG/PC)

0.66

**TYPE U SERIES**

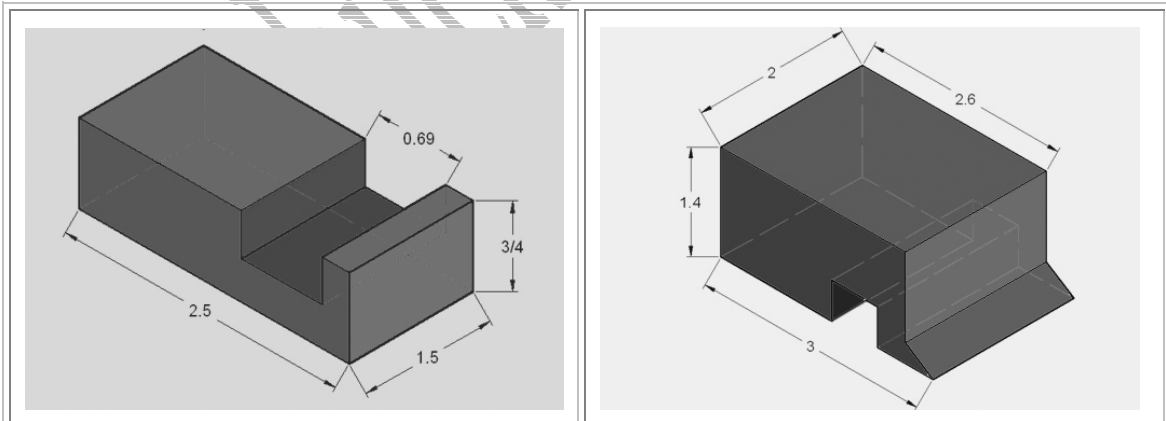

WHABBU001



WHABBU002

N.W. (KG/PC)

0.70

N.W. (KG/PC)

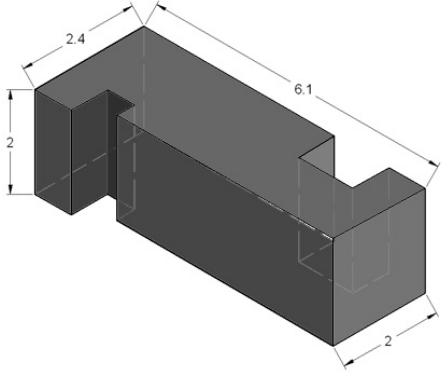
2.0

		
<p>WHABBU003</p>		
<table border="1"> <tr> <td>N.W. (KG/PC)</td> <td>7.45</td> </tr> </table>		N.W. (KG/PC)
N.W. (KG/PC)	7.45	

**TYPE P SERIES**

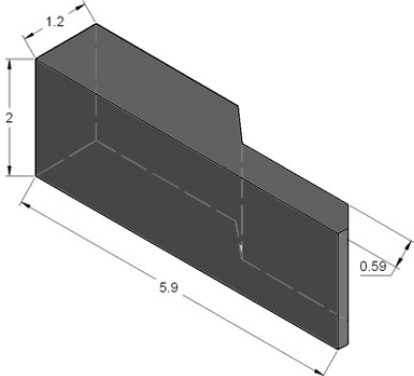
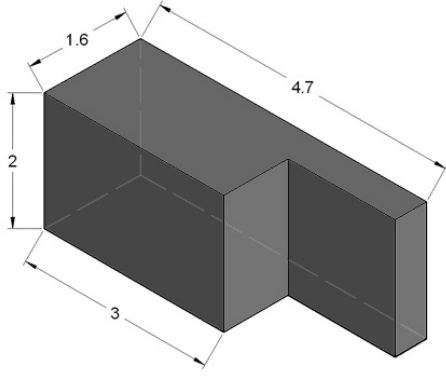
					
<p>WHABBP001</p>	<p>WHABBT002</p>				
<table border="1"> <tr> <td>N.W. (KG/PC)</td> <td>2.80</td> </tr> </table>	N.W. (KG/PC)	2.80	<table border="1"> <tr> <td>N.W. (KG/PC)</td> <td>3.25</td> </tr> </table>	N.W. (KG/PC)	3.25
N.W. (KG/PC)	2.80				
N.W. (KG/PC)	3.25				

**TYPE T SERIES**

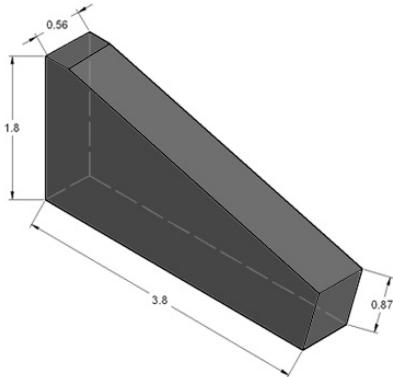
		
<p>WHABBT001</p>		
<table border="1"> <tr> <td>N.W. (KG/PC)</td> <td>1.40</td> </tr> </table>	N.W. (KG/PC)	1.40
N.W. (KG/PC)	1.40	

## Tungsten Bucking bar available for sale

The below is the tungsten bucking bar available from Chinatungsten Online with the most detailed sizes and weights. They were resulted from some formal orders from other clients. If you are interested in our stock, please contact us directly via [sales@chinatungsten.com](mailto:sales@chinatungsten.com) for the best offer.

DWG.NO.	Dimensions (inch)	Q'ty (pcs)	Notes
WHABBH001	4×1×0.63	20	Good
WHABBH002	2.5×1.5×0.75	20	Good
WHABBU001	2.5×1.5×0.75	20	Good
WHABBL001	2×1.5×0.5	20	Good
WHABBH003	3×1.6×0.5	20	Good
WHABBH004	2×1×1	20	Good
WHABBL004	4×2×1	20	Good
WHABBH005	3.5×1.5×1	20	Good
WHABBH006	3.5×1.5×0.4	20	Good
WHABBH010	2×1.5×0.5	20	Good
WHABBH009	3.8×1.2×0.6	20	Good
WHABBL006	3.3×1.2×0.5	20	Good
WHABBH001	4×1×0.63	7	*With slight nick, but available for any riveting applications.
WHABBH001	4×1×0.63	4	
WHABBH002	2.5×1.5×0.75	2	
WHABBU001	2.5×1.5×0.75	2	
WHABBT001	4×1.8×0.9	1	
WHABBH010	2×1.5×0.5	7	Small sizes deviation

**\*For the bucking bars with slight nick, a bit discount can be considered.**