

ARMY RESEARCH LABORATORY



HVOF Application of Nickel and Nickel Alloy to Tungsten Heavy Alloy for Jacketed Penetrators

by John V. Kelley and Russell Kilbane

ARL-TR-3095

November 2003

www.chinatungsten.com

www.chinatungsten.com
NOTICES

Disclaimers

The findings in this report are not to be construed as an official Department of the Army position unless so designated by other authorized documents.

Citation of manufacturer's or trade names does not constitute an official endorsement or approval of the use thereof.

Destroy this report when it is no longer needed. Do not return it to the originator.

Army Research Laboratory

Aberdeen Proving Ground, MD 21005-5069

ARL-TR-3095

November 2003

HVOF Application of Nickel and Nickel Alloy to Tungsten Heavy Alloy for Jacketed Penetrators

John V. Kelley

Weapons and Materials Research Directorate, ARL

Russell Kilbane

Independent Contractor

Report Documentation Page

Form Approved
OMB No. 0704-0188

Public reporting burden for this collection of information is estimated to average 1 hour per response, including the time for reviewing instructions, searching existing data sources, gathering and maintaining the data needed, and completing and reviewing the collection information. Send comments regarding this burden estimate or any other aspect of this collection of information, including suggestions for reducing the burden, to Department of Defense, Washington Headquarters Services, Directorate for Information Operations and Reports (0704-0188), 1215 Jefferson Davis Highway, Suite 1204, Arlington, VA 22202-4302. Respondents should be aware that notwithstanding any other provision of law, no person shall be subject to any penalty for failing to comply with a collection of information if it does not display a currently valid OMB control number.

PLEASE DO NOT RETURN YOUR FORM TO THE ABOVE ADDRESS.

1. REPORT DATE (DD-MM-YYYY) November 2003		2. REPORT TYPE Final		3. DATES COVERED (From - To) January–December 2000	
4. TITLE AND SUBTITLE HVOF Application of Nickel and Nickel Alloy to Tungsten Heavy Alloy for Jacketed Penetrators				5a. CONTRACT NUMBER DAAD17-01-P-0066	
				5b. GRANT NUMBER	
				5c. PROGRAM ELEMENT NUMBER	
6. AUTHOR(S) John V. Kelley and Russell Kilbane*				5d. PROJECT NUMBER 18M43A	
				5e. TASK NUMBER	
				5f. WORK UNIT NUMBER	
7. PERFORMING ORGANIZATION NAME(S) AND ADDRESS(ES) U.S. Army Research Laboratory ATTN: AMSRL-WM-MC Aberdeen Proving Ground, MD 21005-5069				8. PERFORMING ORGANIZATION REPORT NUMBER ARL-TR-3095	
9. SPONSORING/MONITORING AGENCY NAME(S) AND ADDRESS(ES)				10. SPONSOR/MONITOR'S ACRONYM(S)	
				11. SPONSOR/MONITOR'S REPORT NUMBER(S)	
12. DISTRIBUTION/AVAILABILITY STATEMENT Approved for public release; distribution is unlimited.					
13. SUPPLEMENTARY NOTES *Independent contractor.					
14. ABSTRACT In recent years, there has been an increased desire to replace depleted uranium (DU) anti-armor penetrators with tungsten heavy alloy (WHA) penetrators. However, the ballistic performance of WHA does not compare with that of DU. Many methods of improving the ballistic properties of tungsten have been explored. One recent method includes jacketing a long thin core of WHA with a more ductile metal. This report examines the use of thermal-sprayed, high-velocity oxy-fuel coatings to apply the jacket material. However, applying thermal-sprayed coatings onto a tungsten substrate is a challenge. The differences in the coefficients of thermal expansion (CTE) make it difficult to achieve adequate adhesion of most coatings to tungsten. Further compounding the problem are residual stresses inherent in thermally sprayed coatings. The thicker the coating desired, the more likely disbonding will occur upon cooling of the substrate. Early attempts to apply a Ni coating (0.010–0.020 in thick) to a tungsten substrate yielded immediate disbonding and/or cracking of the coatings. The work presented is an investigation focusing on modifications to spray parameters and the use of multiple thin layers to minimize heat transfer and achieve better adhesion. The use of a material with a CTE nearer to that of tungsten as a bond coat and grading of coating materials was also examined as a method for increasing the overall adhesion of the coating system.					
15. SUBJECT TERMS outdoor exposure, marine corrosion, nonchromate, chromate, aluminum armor					
16. SECURITY CLASSIFICATION OF:			17. LIMITATION OF ABSTRACT	18. NUMBER OF PAGES	19a. NAME OF RESPONSIBLE PERSON
a. REPORT UNCLASSIFIED	b. ABSTRACT UNCLASSIFIED	c. THIS PAGE UNCLASSIFIED			UL
					19b. TELEPHONE NUMBER (Include area code) 410-306-0837

Standard Form 298 (Rev. 8/98)
Prescribed by ANSI Std. Z39.18

Contents

List of Figures	iv
List of Tables	iv
1. Introduction	1
2. Experimental Procedure	3
2.1 Specimen Preparation.....	3
2.2 Coating Process.....	3
2.3 Adhesion Testing.....	5
2.4 Visual Examination.....	7
3. Results and Discussion	7
4. Summary, Conclusions, and Recommendations	11
5. References	12
Distribution List	13

List of Figures

Figure 1. Ni-jacketed tungsten penetrator.....	1
Figure 2. Schematic of Sultz Metco Diamond Jet (DJ) HVOF gun.	2
Figure 3. The two sizes of cylindrical (sub-sized penetrator) samples.	4
Figure 4. HVOF unit shown includes 9MP closed loop powder feeder.	4
Figure 5. Schematic of some intermediate layer combinations used.....	6
Figure 6. Schematic of the pull-off adhesion test.	6
Figure 7. Radial cracking of an Ni-coated tungsten core penetrator using the continuous spray method.....	8
Figure 8. Comparison of Ni coating on two different substrates using identical parameters.....	8
Figure 9. Cross section of specimen W2.	8
Figure 10. The residual compressive stress is the result of coldworking done by the impact of subsequent “solid” particles at high velocity.....	9
Figure 11. The peened Ni splats of specimen W2.	9
Figure 12. Bond strength for HVOF-coated tungsten samples. Arrow for chrome coating indicates >3500 psi.	10

List of Tables

Table 1. Coefficients of thermal expansion of materials used in this experiment.....	3
Table 2. HVOF spray parameters using hydrogen as fuel gas.....	5
Table 3. Laboratory conditions for pull-off adhesion ASTM D 4541.....	6

1. Introduction

Since the end of the Gulf War, the North Atlantic Treaty Organization and the United States have been seeking alternatives to the use of both depleted uranium (DU) and lead munitions. One of the most viable alternatives to these materials is tungsten. Tungsten has been used in munitions as far back as the 1940s when Germany used it in WWII. Despite this long history, tungsten's ballistic performance remains inferior to that of DU when used in armor-piercing applications. The unique adiabatic shear properties of DU provide a "self-sharpening" effect when penetrating passive armor systems. Tungsten, while similar to DU in density, tends to "mushroom" on impact. This behavior limits its ability to penetrate armor effectively. One way researchers are trying to enhance the ballistic performance of tungsten is by jacketing or coating a tungsten core with nickel (Ni) and other alloys (Figure 1).

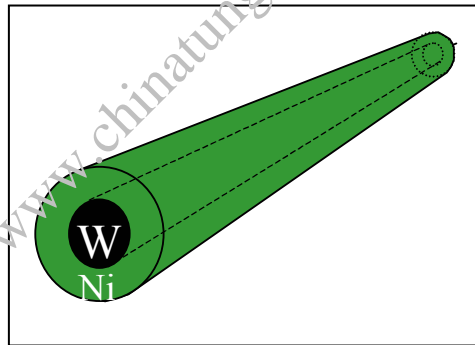

Figure 1. Ni-jacketed tungsten penetrator.

A detailed explanation of how a Ni jacket enhances the ballistic properties of tungsten is beyond the scope of this report. However, one theory is that a thinner tungsten core with a lighter jacket material (1) may be accelerated to higher velocities than a solid tungsten penetrator, (2) concentrates the lethal mass of the penetrator into a smaller impact area, and (3) improves in-flight stability of the round. Therefore, research into efficient and cost-effective methods of coating tungsten is being conducted.

Several methods for applying a jacket to tungsten have been employed. Plating, cladding, and various welding techniques have been used with some success. Thermal spray coatings offer yet another alternative. The process of thermal spraying involves the transport of a coating material to a substrate at high velocities and elevated temperatures. Heated particles (in many cases, molten droplets) of coating materials are accelerated at high speeds and are made to impact a substrate. Successive particles then impact the surface where the high velocity causes the particles to deform and create a mechanical bond with the underlying surface. A coating forms by the layering of individual flattened particles on top of each other. The flattened particles form around surface features and solidify. The coatings often have fine microstructure due to rapid

solidification of the particles. This gives the coatings unique mechanical properties. The bond strength of the droplets can depend upon the coating and substrate material, and the process parameters used to deliver the spray. When a coating material does not have the ability to make a chemical bond with the substrate, it is necessary to roughen the substrate surface in order to enhance the coating's mechanical bond.

One thermal spray technique is the high-velocity oxy-fuel (HVOF) system. This system uses an oxy fuel mixture of either hydrogen, propane, or propylene. A powdered coating material is fed through the back of the gun into an ignited gas mixture. The mixture heats the atomized powder and deposits it on a substrate at particle velocities approaching 3000 ft/s (gas velocities reach 7000 ft/s), and flame temperatures reach 5000 °F (Figure 2). The system's practical use is limited to metal and some ceramics coatings such as aluminum oxide. The HVOF process was chosen for this experiment because of its ability to apply higher density coatings (very low porosity <2%), with higher bond strength, and reduced residual stresses for coatings of greater thickness (1, 2).

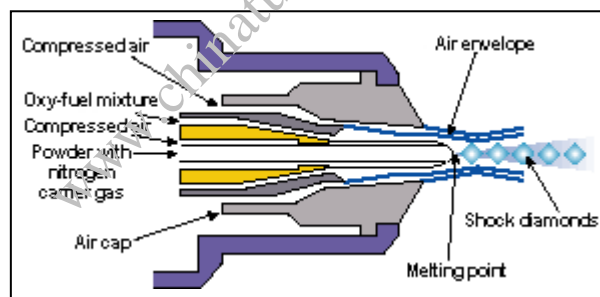

Figure 2. Schematic of Sulzer Metco Diamond Jet* (DJ) HVOF gun.

Using tungsten as a substrate for thermal spray coating presents two challenges. First, tungsten is difficult to abrade, often resulting in profiles of less than the recommended 1 mil. However, the best that could be achieved on the tungsten samples presented in this report was an average surface roughness (R_A) of $9.57 \mu\text{m}$. The low profile surface roughness makes it difficult to achieve a good mechanical bond. Second, tungsten is a refractory metal with a very high melting point and low coefficient of thermal expansion (CTE) relative to the coating material. The differences between the CTE of the materials coupled with the elevated temperatures causes significant thermal stresses at the interface. Table 1 shows the CTE of the materials used in this experiment and equation 1 shows a relationship between CTE and the residual thermal stress (3).

* Sulzer Metco Diamond Jet is a registered trademark of Sulzer Metco Inc., 1101 Prospect Ave., Westbury, NY 11590.

Table 1. Coefficients of thermal expansion of materials used in this experiment.

Material	CTE (in/in °C)
Tungsten	4.6
Nickel	13.3
Chromium	6.2

$$\sigma_{Ni} = \left[\frac{E_w \Delta T (\alpha_{Ni} - \alpha_w)}{E_{Ni} + E_w} \right] * E_{Ni}, \quad (1)$$

where α is the coefficient of thermal expansion, and E is the modulus of elasticity. From equation 1, the residual stress is directly proportional to the change in temperature (ΔT).

Finally, a literature search* revealed little in the way of coatings on tungsten alloys, and none were found that address thermal spray coatings. Therefore, the purpose of this experiment is to investigate ways to reduce the residual stress in the HVOF coating and thereby eliminate cracking of the coatings and maintain good adhesion to the substrate.

2. Experimental Procedure

2.1 Specimen Preparation

Two specimen types were used in the experiment: a flat specimen, and a cylindrical specimen (Figure 3). The flat specimen was necessary to conduct pull off adhesion tests on the HVOF coatings. Because the initial objective of this effort was to examine the feasibility of using the HVOF coatings for jacketed penetrators, subsized tungsten and steel rods were coated and metallographically examined and compared. The two coating materials were Metco powders: Amdry Pure Chrome #05063, and pure Ni #56F-NS. Prior to the application of the coatings, tungsten substrate was grit blasted using a #20 grit aluminum oxide medium with the nozzle positioned $\sim 90^\circ$ to the sample surface. The samples were cleaned in acetone using an ultrasonic cleaner, then rinsed with deionized water, and immediately dried under a hot air blower. The final surface profile was then measured using a Rank Taylor Hobson Form Talysurf Series profilometer.

2.2 Coating Process

The HVOF system used in the experiment was a Sulzer Metco DJ. This system includes a robot-mounted DJ gun, 9MP powder feeder, and DJ control unit. Figure 4 is a picture of the system used in this experiment. The spray parameters for each sample are given in Table 2.

* Authors searched ARL Desktop Services/Technical Library Web of Knowledge and executed a general Internet search on Google.

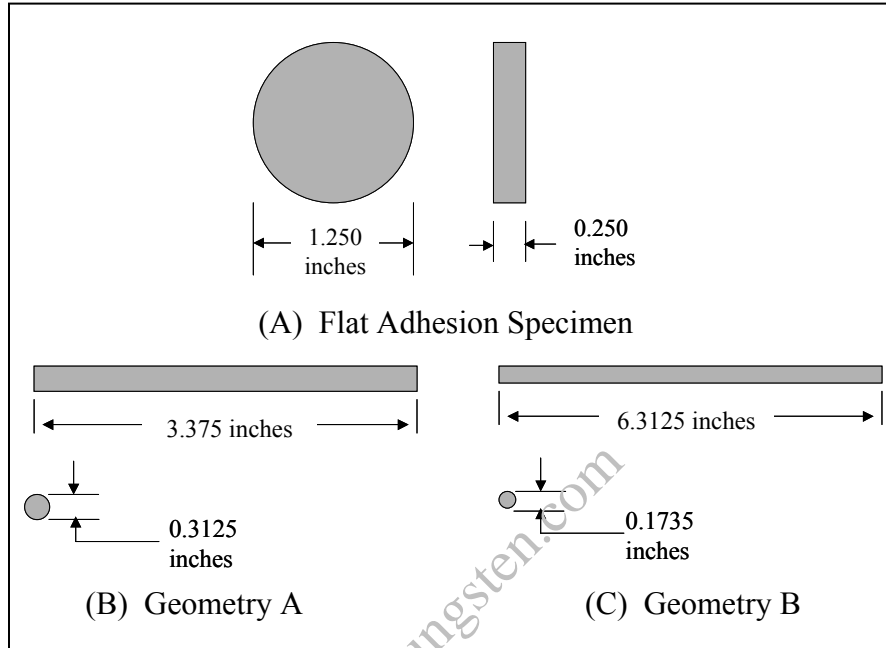

Figure 3. The two sizes of cylindrical (sub-sized penetrator) samples.

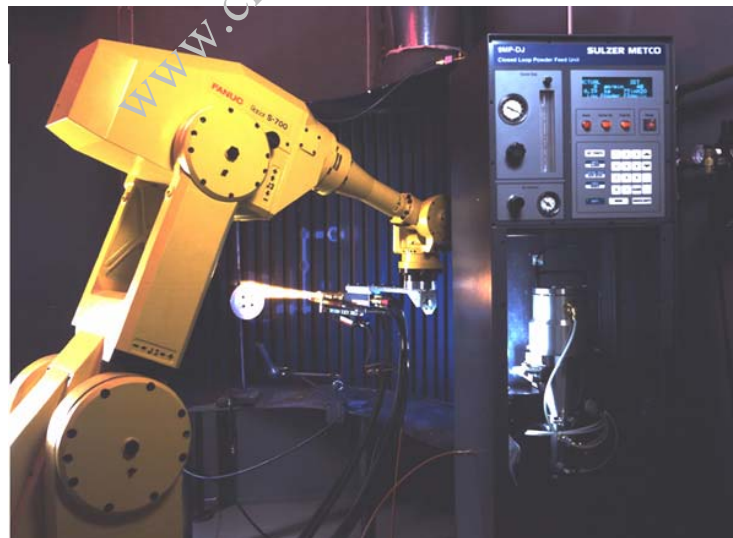

Figure 4. HVOF unit shown includes 9MP closed loop powder feeder.

All cylindrical specimens were sprayed while rotating at ~ 60 rpm. The flat specimens were secured in a vise with surface normal to the DJ gun nozzle. The cooling jets were positioned 24 in from the specimen, blowing on the front and rear surfaces. Hydrogen was used as the fuel gas for all specimens. All specimens were labeled and identified as shown in Table 2. The spray parameters were controlled using a Sulzer Metco DJ control DJ Automatic Control System and the respective spray parameters for each specimen are also listed in Table 2.

Table 2. HVOF spray parameters using hydrogen as fuel gas.

HVOF Coatings Spray Parameters								
Specimen ID #	S1	W1	W2	W3	W4	W5	W6	W7
Geometry	CylA	CylA	CylB	Flat	Flat	Flat	Flat	Flat
Substrate	Steel	W	W	W	W	W	W	W
Powder type	Ni	Ni	Ni	Ni	Cr	Cr/Ni	Mixed	Graded
Hydrogen flow rate (FMR)	62	62	62	62	55	55	55	55/62
Hydrogen pressure (psig)	140	140	125	125	125	125	125	125
Oxygen flow rate (FMR)	32	32	32	32	42	42	42	42/32
Oxygen pressure (psig)	170	170	170	170	170	170	170	170
Air flow rate (FMR)	44	44	44	44	40	40	40	40/44
Air pressure (psig)	100	105	105	105	105	105	105	105
Carrier flow rate (FMR)	55	45	45	45	45	45	45	45
Powder feed rate (lb/hr)	12	12	10	10	6	11	11	11
Traverse speed (mm/s)	600	600	100	100	800	600	600	600
Spray distance (in)	10	10	10	10	12	12	12	10–12
Preheat passes	2	2	0	0	0	1	1	1

In Table 2, the coatings for specimen S1 and W1 were applied using several consecutive spray passes. No cooling of the specimen was allowed between each layer. The coatings on samples W2–W7 were applied in a slightly different manor. An ~0.005-in layer was applied and allowed to cool to room temperature. The process was continued until the final coating thickness was achieved.

Material modifications were also made in an attempt to increase the adhesion strength of the coatings. Intermediate layers with CTEs closer to that of the tungsten were introduced at the interface. These layers were intended to act as bond coats for the Ni.

Three bond coat configurations were examined: (1) chromium (Cr), (2) 50-50 volume % of Cr- and Ni-mixed powder, and (3) a “graded” coating system consisting of a chrome underlayer, a 50-50 volume % of Cr- and Ni-mixed powder and an Ni top layer. Figure 5 illustrates the intermediate layer configurations.

2.3 Adhesion Testing

Pull-off adhesion tests were performed using a hydraulic adhesion test apparatus (HATE) Mark VII coating adhesion tester (Figure 6) in accordance with American Society for Testing and Materials (ASTM) D 4541 (4). A loading fixture commonly referred to as a “dolly” was secured normal to the coating surface using a cyanoacrylate adhesive. After allowing the adhesive to cure for 24 hr in laboratory conditions (Table 3), the attached dolly was inserted into the test apparatus. The load applied by the apparatus was gradually increased and monitored on the gauge until a plug of coating was detached. The failure value in lb/in² (psi) was recorded and the failure mode characterized.

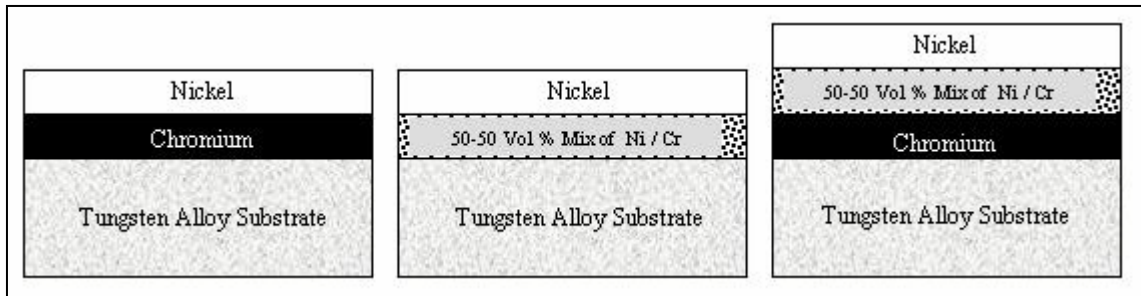

Figure 5. Schematic of some intermediate layer combinations used.

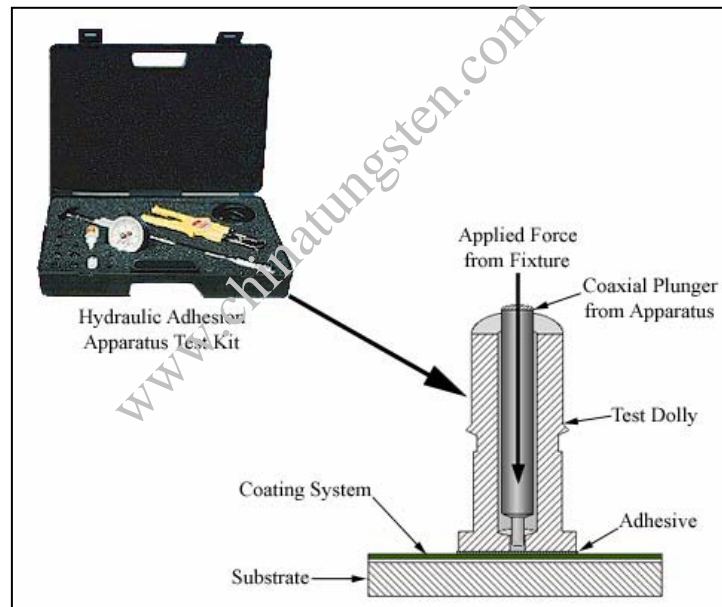

Figure 6. Schematic of the pull-off adhesion test.

Table 3. Laboratory conditions for pull-off adhesion ASTM D 4541.

Adhesive Type	Cyanoacrylate
Cure time (hr)	24
Temperature (°C)	25
Relative humidity (%)	31
Substrate materials	Tungsten heavy alloy
Coating type	HVOF

Note: For this test to be accurate, the substrates must be of sufficient thickness to ensure that the coaxial load applied during the removal stage does not distort the substrate material and cause a bulging or a “trampolining effect.” On a thin specimen, the resultant bulge causes the coating to radially peel away outwards from the center instead of uniformly pulling away in pure tension and thus results in significantly lower readings. All of the samples substrates used in this study were made from ~0.250-in-thick tungsten and were of adequate thickness and stiffness for this pull-off test procedure (5).

2.4 Visual Examination

Throughout the spraying process all specimens were visually inspected after each layer was allowed to cool to determine if any cracking or debonding of the coating occurred. Visual examinations were also performed following the pull-off adhesion tests. The mode of failure for each coating was observed and recorded.

3. Results and Discussion

Initial coating attempts using uninterrupted deposition on flat tungsten substrates resulted in catastrophic failures. Because of the differences in CTE, the increased temperature and subsequent cooling of the sample to room temperature created a shear stress at the coating/substrate interface. As the sample cooled, the shear stress increased until it exceeded the coating bond strength, and the coating “popped” off.

Similar attempts to spray cylindrical tungsten samples resulted in cracked coating upon cooling. Steel and tungsten penetrator cores were sprayed with Ni. These specimens were cross-sectioned and compared under an optical microscope. Figure 7 shows the radial cracking that formed in the Ni jacket surrounding the tungsten core. In Figure 8, a closer look at the interface shows the presence of gaps and voids between the Ni coating and tungsten substrate. However, when a steel cylindrical substrate with a CTE that is closer to Ni is coated using identical process parameters, there is no cracking, and an excellent bond is achieved (Figure 8b). It was evident that the CTE disparity is a factor and some process parameters needed to be adjusted.

In order to reduce the maximum ΔT during spraying, the coatings were applied using several thin layers. Each layer was allowed to cool to room temperature before the next layer was applied. Subsequent layers were built up until the final coating thickness was achieved. All specimens produced using multiple interrupted layers were examined under 100 \times magnification for cracks or separation at the interface. In all cases, there was no significant cracking observed. Figure 9 shows the cross section of specimen W2 (Ni on tungsten), which was produced using multiple interrupted layers.

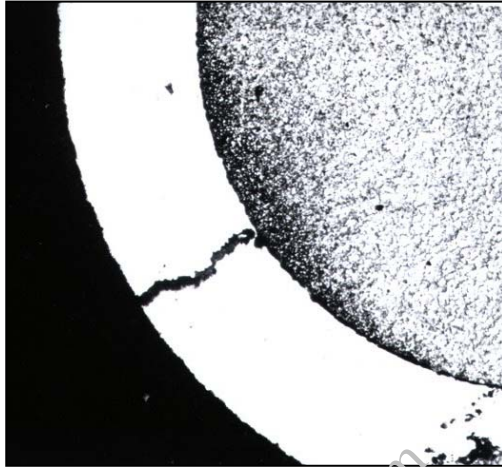
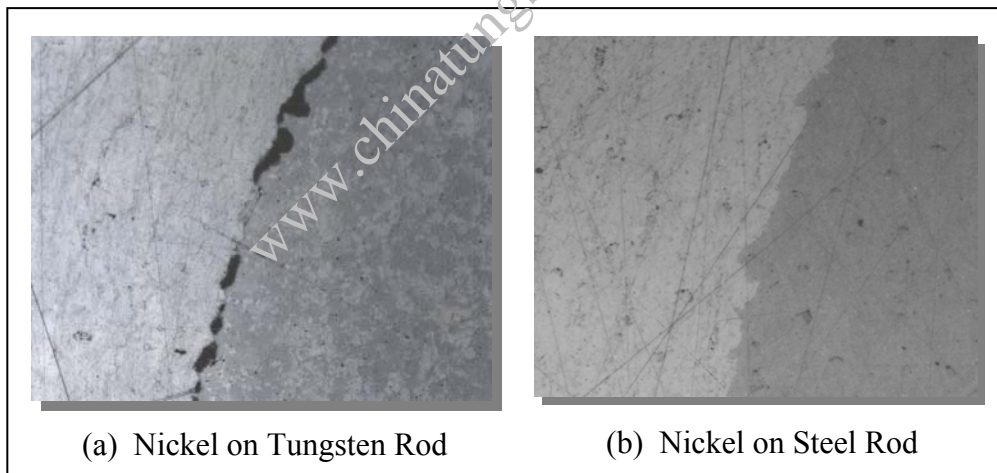

Figure 7. Radial cracking of an Ni-coated tungsten core penetrator using the continuous spray method.



(a) Nickel on Tungsten Rod

(b) Nickel on Steel Rod

Figure 8. Comparison of Ni coating on two different substrates using identical parameters.



Figure 9. Cross section of specimen W2.

When the coating is allowed to cool to room temperature between layers, the HVOF coating maintains more of its compressive residual stress. The coldworking (peening) of the particles by the impact of subsequent particles causes the residual compressive stress, which somewhat offsets the tensile stresses induced by the different CTE (Figure 10). The peening effect can be seen by the more rounded droplet splats of the coating in Figure 11.

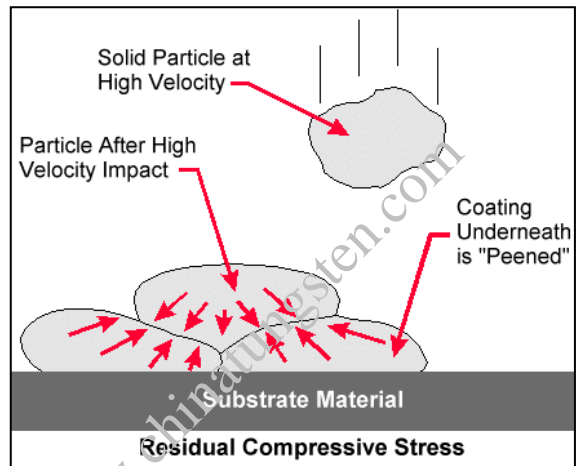

Figure 10. The residual compressive stress is the result of coldworking done by the impact of subsequent "solid" particles at high velocity.*

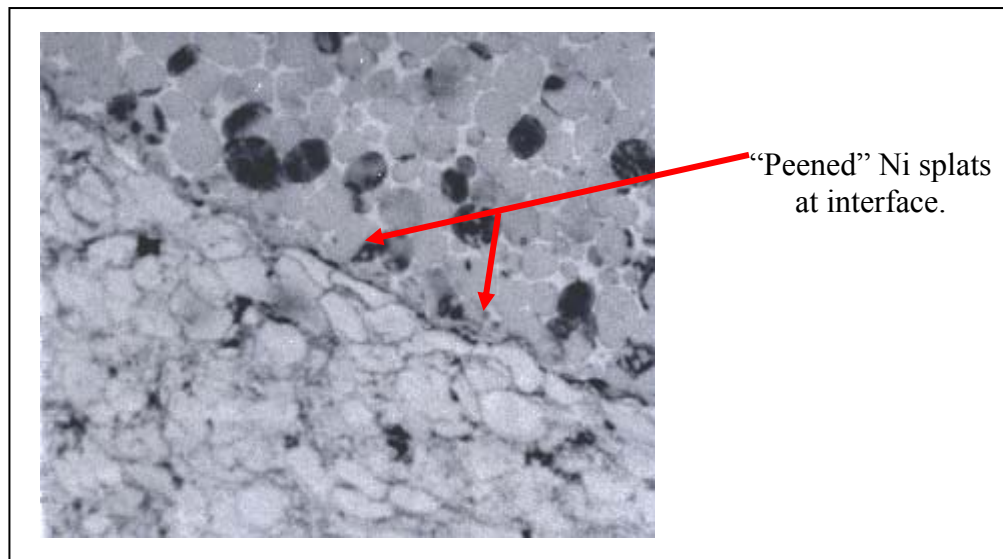

Figure 11. The peened Ni splats of specimen W2.

* Illustration courtesy of Sulzer Metco Inc., 1101 Prospect Ave., Westbury, NY 11590; www.sulzer.com.

Conversely, the coatings applied without a cooling period between layers show a more elongated, flatter splat. This is most likely because the coating and substrate are under the flame and at higher temperature for a longer time. The splats become further softened by the elevated temperatures and flattened by the impact of subsequent layers. The initial residual compressive stress caused by the peening is relieved. Thus upon cooling, the residual tensile stress increases. The greater the ΔT of the substrate and coating “system,” the greater the residual tensile stress will be. The two tensile stresses are coupled together, and when they exceed either the adhesion strength of the coating or the tensile strength of the coating material, failure occurs.

As mentioned earlier (Figure 5), three bond coat configurations were examined. Figure 12 shows the results of the HATE adhesion tests of these coatings. Here it can be seen that the Cr (chrome) coating achieved the highest bond strength at >3500 psi. All specimens with a Cr “bond” coat had better adhesion strength than specimens with Ni applied directly to the tungsten substrate. The reason for this is that the CTE of the Cr is closer to that of the tungsten than any of the other coatings. This resulted in less shear stresses developing at the interface and lower tensile stresses in the coating material.

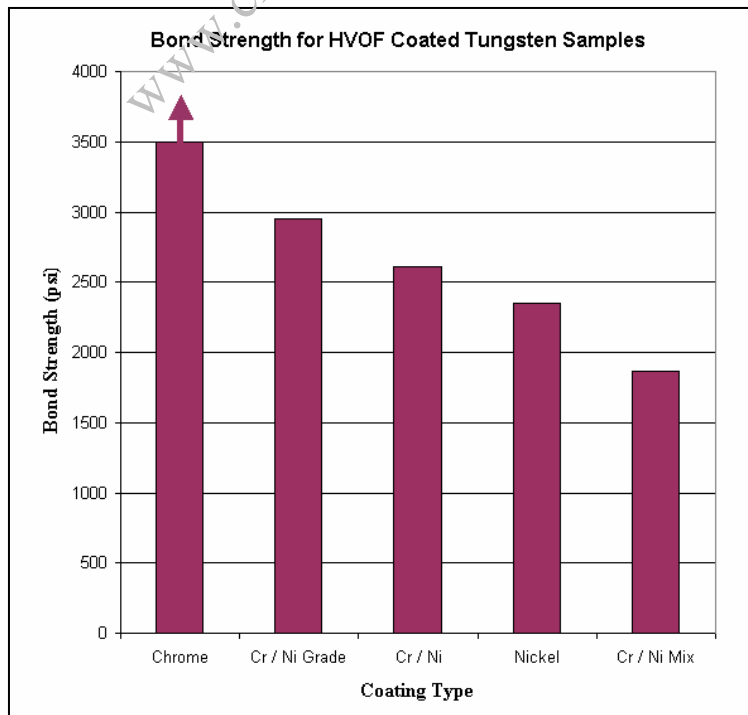

Figure 12. Bond strength for HVOF-coated tungsten samples. Arrow for chrome coating indicates >3500 psi.

4. Summary, Conclusions, and Recommendations

The larger the CTE mismatch between substrate and coating, the greater the problem with residual stress and thus the more difficulty obtaining good adhesion. The cumulative residual stress is reduced when the ΔT of the coating and substrate during the application process is reduced. This was achieved by interrupting the coating process to allow for cooling between layers. The building up of thinner coating layers to reach the desired thickness is an effective way of minimizing ΔT . The addition of a bond coat can enhance coating adhesion. However, in this case, an intermediate layer of Cr only slightly increases the overall adhesion strength of the coating.

www.chinatungsten.com

5. References

1. *Compressive Stresses in JP-5000 Coatings*; TAFE Technical Bulletin 22.1.0.3; Hobart Tafa Technologies Inc.: Concord, NH.
2. Lau, M. L.; Jiang, H. G.; Nuchter, W.; Lavernia, E. J. Thermal Spraying of Nanocrystalline Ni Coatings. *Solidi Status Physica* **1998**, 257–268.
3. Flinn, T.; Trojan, P. *Engineering Materials and Their Applications, 4th Edition*; Houghton Mifflin: NY, 1990; pp 141–148.
4. ASTM D 4541. Standard Test Method for Pull-Off Strength of Coated Specimens Subjected to Corrosive Environments. *Annu. Book ASTM Stand.* **1989**.
5. Kelley, J. V.; Placzankis, B. E. Outdoor Exposure Results for Pretreated and Topcoated Aluminum Armor Alloys 2519, 5083, and 7039. *Proceedings of the 2001 Triservice Corrosion Conference*, San Antonio, TX, January 2001.

NO. OF COPIES ORGANIZATION

NO. OF COPIES ORGANIZATION

2 DEFENSE TECHNICAL
INFORMATION CENTER
DTIC OCA
8725 JOHN J KINGMAN RD
STE 0944
FT BELVOIR VA 22060-6218

ABERDEEN PROVING GROUND

2 DIR USARL
AMSRL CI LP (BLDG 305)
AMSRL CI OK TP (BLDG 4600)

1 COMMANDING GENERAL
US ARMY MATERIEL CMD
AMCRDA TF
5001 EISENHOWER AVE
ALEXANDRIA VA 22333-0001

1 INST FOR ADVNCD TCHNLGY
THE UNIV OF TEXAS AT AUSTIN
3925 W BRAKER LN STE 400
AUSTIN TX 78759-5316

1 US MILITARY ACADEMY
MATH SCI CTR EXCELLENCE
MADN MATH
THAYER HALL
WEST POINT NY 10996-1786

1 DIRECTOR
US ARMY RESEARCH LAB
AMSRL D
DR D SMITH
2800 POWDER MILL RD
ADELPHI MD 20783-1197

1 DIRECTOR
US ARMY RESEARCH LAB
AMSRL CS IS R
2800 POWDER MILL RD
ADELPHI MD 20783-1197

3 DIRECTOR
US ARMY RESEARCH LAB
AMSRL CI OK TL
2800 POWDER MILL RD
ADELPHI MD 20783-1197

3 DIRECTOR
US ARMY RESEARCH LAB
AMSRL CS IS T
2800 POWDER MILL RD
ADELPHI MD 20783-1197

NO. OF
COPIES ORGANIZATION

1 US ARMY SOLDIER SYSTEMS CENTER
R KILBANE
KANSAS ST
NATICK MA 01760

ABERDEEN PROVING GROUND

5 DIR USARL
AMSRL WMMC
J KELLEY (4 CPS)
AMSRL WM TC
L MAGNESS

www.chinatungsten.com